

# C10-7×9

## 技术规格书 TECHNICAL SPECIFICATION (产品代号/Code )

### A) 吸气剂成份 GETTER COMPOSITION

成分 1 Component 1 : CaO

### B) 容器材料 CONTAINER COMPOSITION

无纺布 : Non-Woven Fabrics

### C) 吸气剂尺寸 GETTER DIMENSIONS

参见附后的图纸 No. P02080000, 版本号 1.0  
See drawings No. P02080000, Rev1.0 herewith enclosed.

### D) 吸气剂特性 GETTER CHARACTERISTICS

总重量(名义)Total Getter Weight (nominal) : 11.2 g  
成分 1 Component 1 Weight (nominal) : 10 g

### E) 吸气特性 SORPTION PERFORMANCE <sup>(1)</sup>

可以吸收的气体 H<sub>2</sub>O, CO<sub>2</sub>  
最大吸水量 Max moisture pickup ≥28%  
二氧化碳最大吸收量 Max Carbon Dioxide pickup 2100 Pa · L  
典型吸气性能曲线见 JS-XB-000062, 版本号 1.1 <sup>(1)</sup>  
As per sorption curve JS-XB-00062, Rev1.1 herewith enclosed.

### F) 标识 IDENTIFICATION

产品通过粘在包装上的标签中的描述和数字进行标识  
The product is identified by the description and the numbers printed on the label stuck on packing.

#### **罐号 Ref. no.**

每个包装上的流水号

Progressive number of each packing.

**批号 Lot no.**

要求产品技术支持时必须提到的号码

Number to be mentioned in case of any technical request on the product.

**数量 Quantity**

在包装中所包含的所有产品数

The number describes the total getters quantity contained inside the packing.

**日期 Date**

包装日期 Packing date.

**产品描述 Product description**

产品型号 Product name.

**G) 包装 PACKING**

产品密封于真空包装的铝塑复合袋中。

The getters are contained into a Al-plastic bag.

**H) 储存条件 STORING CONDITION**

铝塑复合袋放在大气中(温度 25°C,相对湿度 50%)的时间不应超过 1 年, 否则应储存在惰性气体中。

Al-plastic bag can be exposed in open air (namely 25°C and 50% H.R.) for no more than 1 year. Under more severe ambient conditions is advisable to store the getters in inert gases.

**I) 产品或材料的处理 PRODUCT or MATERIAL HANDLING**

按照产品的材料安全数据表处理

Refer to product Material Safety Data sheet.

Prepared:	Checked:	Approved:
-----------	----------	-----------

南京华东电子真空材料有限公司拥有设计和更改版权  
 DESIGN AND PROPERTY OF NANJING HUADONG ELECTRONICS VACUUM MATERIAL CO., LTD.  
 没有本公司的书面许可，不得复制或传播  
 Reproduction or Communication without the company's written permission is Forbidden

Dept. / 部门	SIGN. / 会签

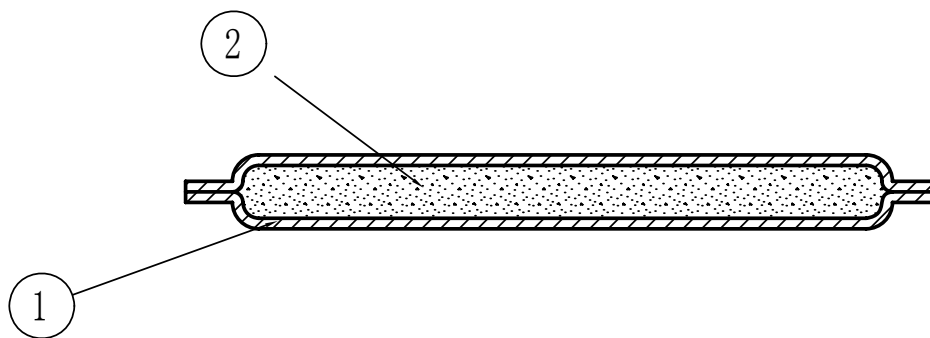
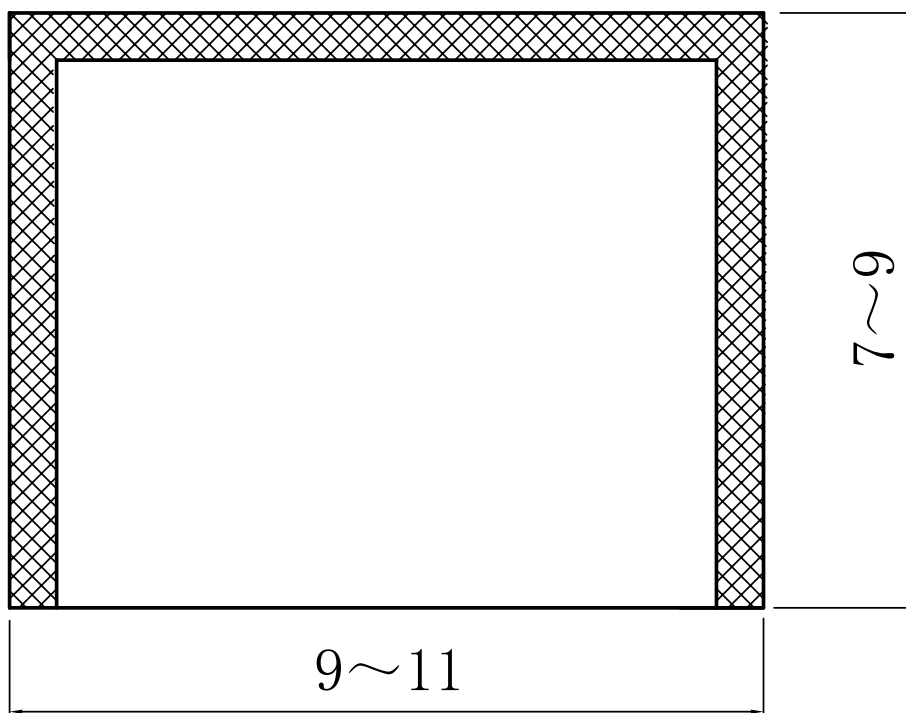

g	10			GETTER MIXTURE/合金粉材: CaO	②
只	1			GETTER CONTAINER/吸气容器: Non-Woven Fabrics/无纺布	①
UN/单位	Q/数量	CODE/代码	IDENTIFYNG NO/识别号	NOMENCLATURE/GROUP 名称/材料	FIND

PARTS LIST/部件列表

			DWN/制图	CHK/审核	APPD/批准	DATE/日期 14-05-30	
			TITLE/名称				SCALE/比例 2:1
			C10-7×9装配图				SIZE/尺寸 A4
NEXT ASSY/继装于	USED ON/用于						
		TOLL. /公差等级	Folder/文件夹 D:\Product\P0209		Dept. /部门 Tech/技术部		
DIMENSIONS ARE IN MILLIMETERS/单位:毫米			DWG NO/图纸号 P02090000		R. /版本 1.0	CODE/代码	
MOD. NO	M1053.0						



## C□-△×◇型吸气剂

空气中典型吸着特性曲线/Typical Sorption Curves in air

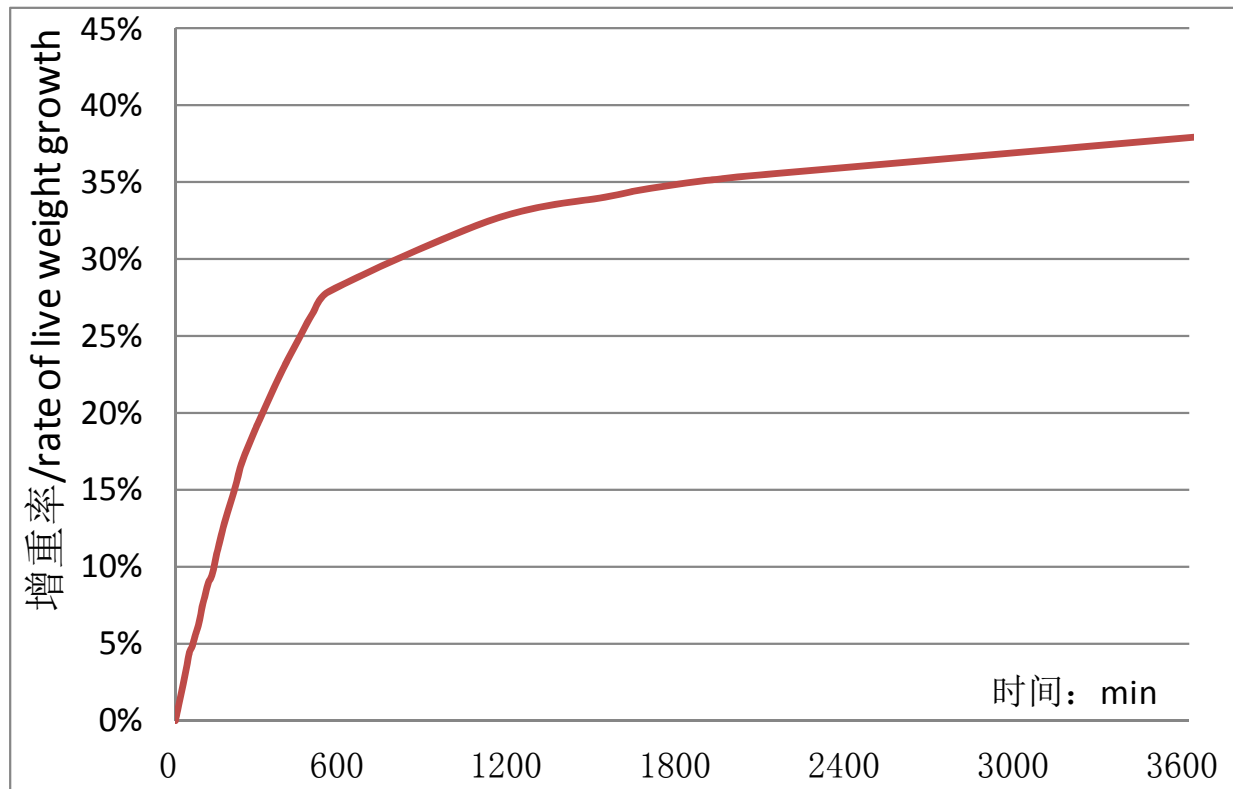

测试条件/Sorption: 25°C

文件编号/Ref. JS-XB-000062, Rev. 1.1 2014-03-18

吸气性能测试依据 JS-GG-000166 / Sorption Test performed according to JS-GG-000166

拟制/Prep.

审核/CHK.

批准/Appr.